

ZC-GW-USB-EM

Gateway Modbus USB – ZigBee



Key Features

- Protocol converter from Modbus/RTU to ZigBee
- USB interface
- Coordinator function for a ZigBee network
- Local memory stores battery powered sensors data
- Transparent bridge towards other Modbus devices
- External antenna
- Power supplied from the USB port

The Gateway Modbus USB is part of the family of 4-noks wireless ZigBee devices. Its purpose is to be an interface between a Personal Computer and the network of 4-noks ZigBee devices using an universal standard protocol such as Modbus/RTU via USB port. The use of Modbus protocol guarantees an immediate use of many commercial Scada for PC.

The device is supplied directly from the USB port; its role in the ZigBee network is Coordinator, i.e. it forms an active part in creating the network and maintaining wireless traffic from and to other similar devices. Furthermore it can function as parent device for battery sensors of the same family and saves data that they asynchronously send regardless of Modbus requests.

If connected with the bridge ZR-BR-485-EM, this gateway offers a full transparent Modbus channel.

Typical Application

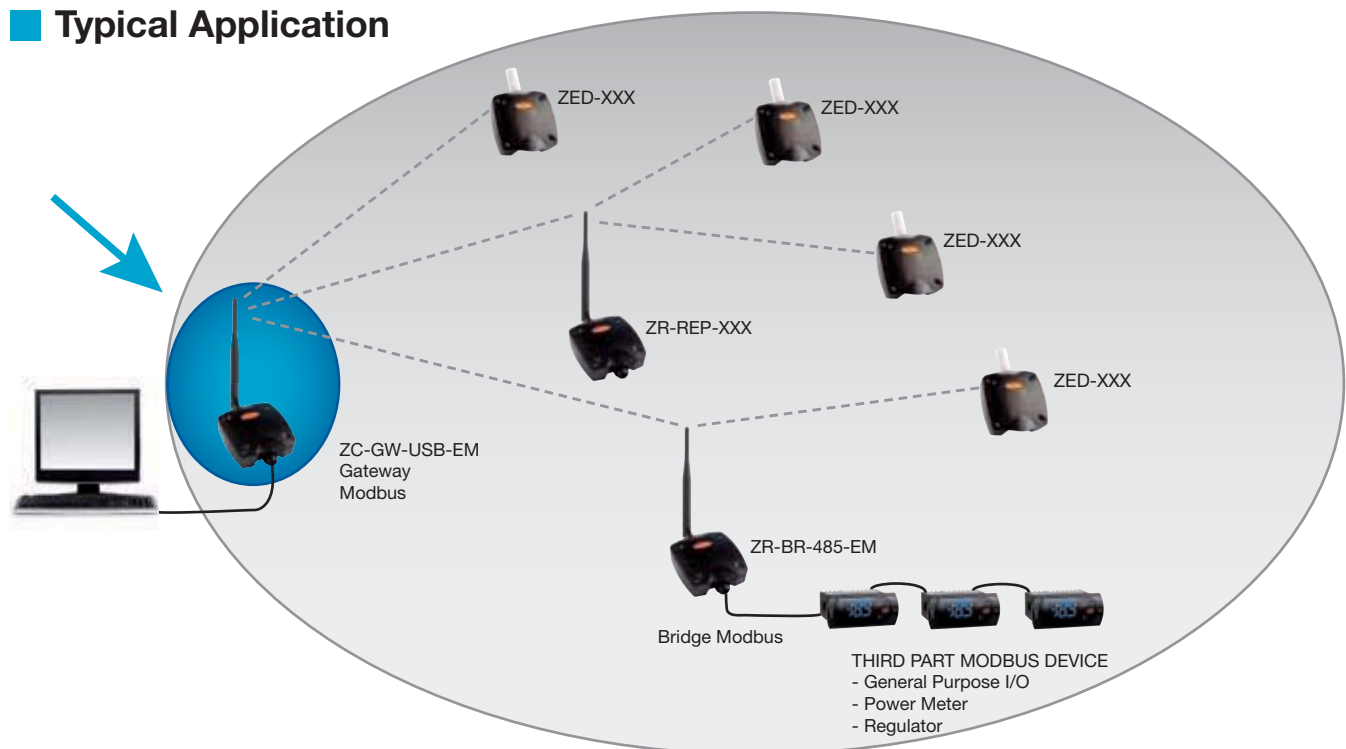

■ Technical Specs

| | |
|---|---|
| General characteristics | Chip Ember EM2420 Compatible IEEE 802.15.4 Stack EmberZnet 3.4.x (ZigBee PRO) Modbus/RTU |
| RF characteristics | Frequency: 2405 MHz ÷ 2480 MHz Modulation: DSSS Nominal transmission power: 1mW (0 dBm) Reception sensitivity: -92 dBm Extern antenna Gain: 5,5 dB Coverage outdoor/indoor: 100m/30m |
| Supply | +5 Vdc from USB; 50mA |
| Connections | USB 2.0 |
| Environment parameters | Operating temperature: -10 ÷ +60°C; <80% U.R. not condensing Storage temperature: -20 ÷ +70°C; <80% U.R. not condensing Degree of protection: IP 50 |
| Compliant with 2006/95/EEC, 89/336/EEC, 99/5/EEC directives Reference Norms: | ETSI EN 300 328: Radio Compatibility for digitals wide band transmissions ETSI EN 301 489: Radio Compatibility EN 61000-6-2: Electromagnetic Compatibility - Emissions EN 61000-6-3: Electromagnetic Compatibility - Immunity EN 60950-1: Electric Safety |

■ Dimensions (mm)

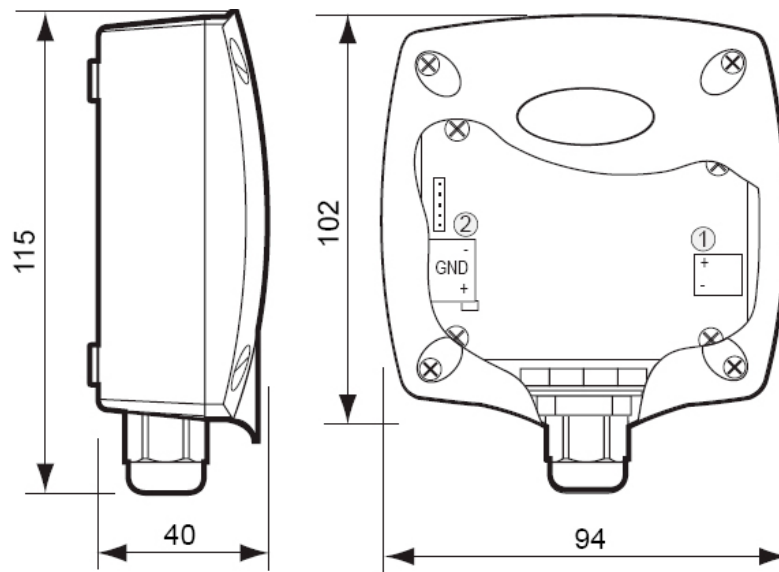

Rev. 2.4 30/09/2009

 **ZB-Connection** is a 4-noks brand

4-noks is a  **ZigBee**
Member

4-noks

4-noks Distributor:

4-noks s.r.l.
Via Dei Gelsi, 19
31010 Godega di Sant'Urbano - Treviso - Italy
Tel. (+39) 0438.1910013
info@4-noks.com - www.4-noks.com