

ZED-TIDCI-M

ZigBee S0 pulse counter



Key Features

- 2 pulse counter inputs S0 compatible
- 2 thermal resistor inputs (NTC resistors not included)
- Sampling and transmission rates are configurable
- Battery powered
- Internal antenna

The ZED-TIDCI-M is a battery powered ZigBee device, capable to count pulses emitted from flow rate meters (water, gas, electricity,...) and to measure the temperature from both the 2 on board NTC inputs . Pulse counters and temperature samples are sent at regular intervals to a gateway of 4-noks products family.

Moreover, if temperature sensors are installed into an hydraulic circuit in the inlet and outlet pipes this device can send the difference between them.

Typical Application

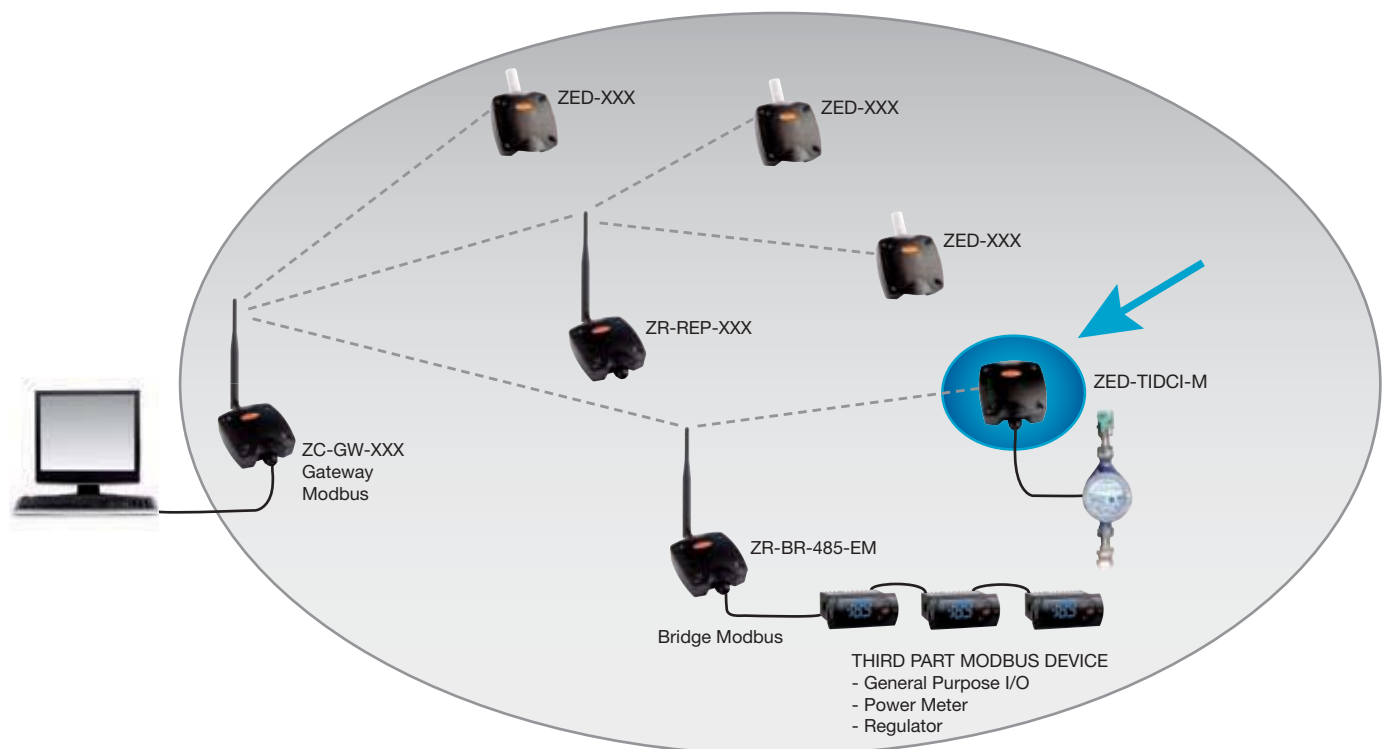

Technical Specs

General characteristics	Chip Ember EM250 Compatible IEEE 802.15.4 Stack EmberZnet 3.4.x (ZigBee PRO) Modbus/RTU Device address settable via internal dip-switch Wall mounting with screws Cable gland: PG9
RF characteristics	Frequency: 2405 MHz ÷ 2480 MHz Modulation: DSSS Nominal transmission power: 2mW (3 dBm) Reception sensitivity: -95 dBm Internal antenna gain: 0 dB Coverage outdoor/indoor: 100m/30m
Supply	AA high energy density lithium battery 3,6V/2000mAh Battery life: 2 years in case of 1 transmission per minute at 20°C
NTC thermal resistor input	NTC type resistor 103AT type (R25 = 10 KOhm; Beta = 3435K) Measurement range: -50°C ÷ +110°C Measurement resolution: 0,1°C Measurement accuracy : ±0,5°C Measures are linearized at tenth of degree
Digital inputs	Electronic type not insulated inputs for clean contact Short circuit current 0,01mA. Use self-cleaning contact
Connections	Pull out terminals (3,81 mm pitch)
Environment parameters	Operating temperature: -10 ÷ +60°C; <80% U.R. not condensing Storage temperature: -20 ÷ +70°C; <80% U.R. not condensing Degree of protection: IP 55
Compliant with 2006/95/EEC, 89/336/EEC, 99/5/EEC directives Reference Norms:	ETSI EN 300 328: Radio Compatibility for digitals wide band transmissions ETSI EN 301 489: Radio Compatibility EN 61000-6-2: Electromagnetic Compatibility - Emissions EN 61000-6-3: Electromagnetic Compatibility - Immunity EN 60950-1: Electric Safety

Dimensions (mm)

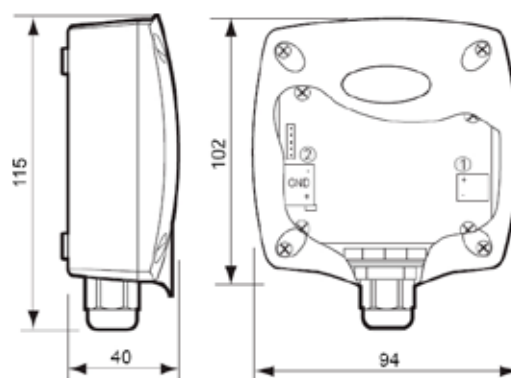

Rev 2.4 30/09/2009

 **ZB-Connection** is a 4-noks brand

4-noks is a  **ZigBee**
Member

4-noks

4-noks Distributor:

4-noks s.r.l.
Via Dei Gelsi, 19
31010 Godega di Sant'Urbano - Treviso - Italy
Tel. (+39) 0438.1910013
info@4-noks.com - www.4-noks.com