

ZC-GW-485-EM

Gateway Modbus RS485 - ZigBee



Key Features

- Protocol converter from Modbus/RTU to ZigBee
- Standard ModBus RS485 interface
- Coordinator function for a ZigBee network
- Local memory stores battery powered sensors data
- Transparent bridge towards other Modbus devices
- External antenna

Gateway Modbus RS485 is part of the family of 4-noks wireless ZigBee devices. Its purpose is to be an interface between a PLC (Programmable Logic Control) or a Personal Computer and the network of 4-noks ZigBee devices using an universal standard protocol such as Modbus/RTU via RS485 serial interface. The use of Modbus protocol guarantees an immediate use of all commercial PLC and many Scada for PC.

Its role in the ZigBee network is Coordinator, i.e. it forms an active part of creating the network and maintaining wireless traffic from and to other similar devices. Furthermore it can function as parent device for battery powered sensors of the same family and saves data that they asynchronously send regardless of Modbus requests.

In conjunction with the bridge ZR-BR-485-EM, this gateway offers a transparent Modbus channel.

Typical Application

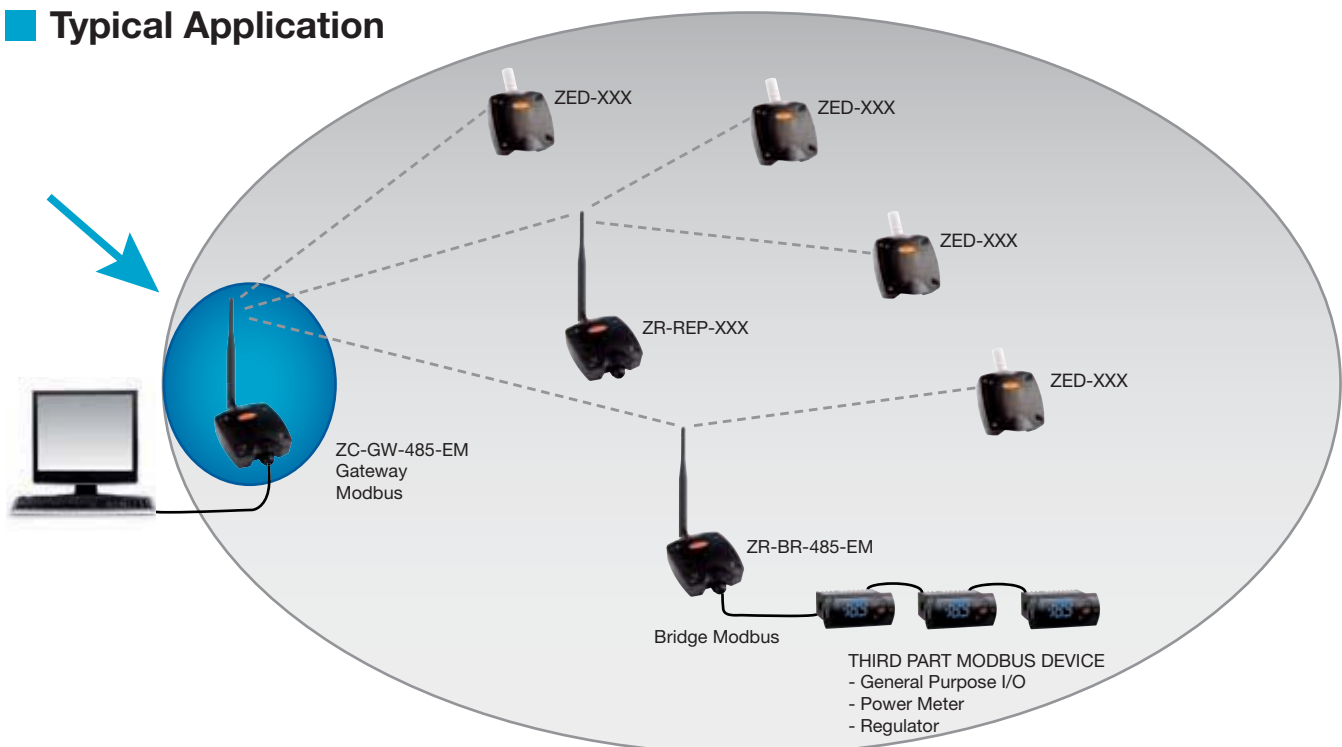

■ Technical Specs

General characteristics	Chip Ember EM2420 Compatible IEEE 802.15.4 Stack EmberZnet 3.4.x (ZigBee PRO) Modbus/RTU
RF characteristics	Frequency: 2405 MHz ÷ 2480 MHz Modulation: DSSS Nominal transmission power: 1mW (0 dBm) Reception sensitivity: -92 dBm Extern antenna Gain: 5,5 dB Coverage outdoor/indoor: 100m/30m
Supply	12-24 Vcc/Vca (±10%); 100mA; 50/60Hz
Connections	RS485 with pull out terminals (3,81 mm pitch)
Environment parameters	Operating temperature: -10 ÷ +60°C; <80% U.R. not condensing Storage temperature: -20 ÷ +70°C; <80% U.R. not condensing Degree of protection: IP 55 ⁽¹⁾
Compliant with 2006/95/EEC, 89/336/EEC, 99/5/EEC directives. Reference Norms:	ETSI EN 300 328: Radio Compatibility for digital wide band transmissions ETSI EN 301 489: Radio Compatibility EN 61000-6-2: Electromagnetic Compatibility - Emissions EN 61000-6-3: Electromagnetic Compatibility - Immunity EN 60950-1: Electric Safety

⁽¹⁾ This protection degree is preserved only if a unique cable with external section less than 8 mm is used for both supply and RS485 signals.

■ Dimensions (mm)

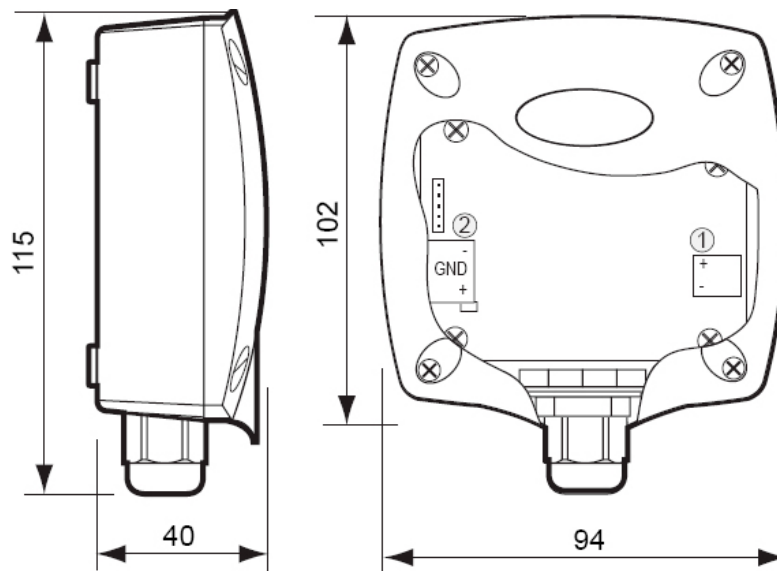

Rev 2.4 30/09/2009

 **ZB-Connection** is a 4-noks brand

4-noks is a  **ZigBee**
Member

4-noks

4-noks Distributor:

4-noks s.r.l.
Via Dei Gelsi, 19
31010 Godega di Sant'Urbano - Treviso - Italy
Tel. (+39) 0438.1910013 - info@4-noks.com