

ZED-TID-M

ZigBee module with 2 NTC inputs and 2 digital inputs



Key Features

- Input for two NTC temperature sensors (not included)
- Two digital inputs
- Alarm thresholds
- Sampling and transmission rates are configurable
- Battery powered
- Long life battery
- Internal antenna

The ZED-TID-M is a battery powered ZigBee device which can read at the same time the temperature with the 2 on board NTC inputs and the 2 digital inputs and send them at regular intervals to one of a Gateway of the 4-noks products family.

This device may be configured to manage alarm thresholds when exceeding maximum or minimum levels of temperature. It is also possible to adjust the sampling and data transmission rate to improve battery life.

This device can perform data transmissions automatically and immediately (regardless of configured sampling rate) in order to signal a status change in one of the two digital inputs.

Typical Application

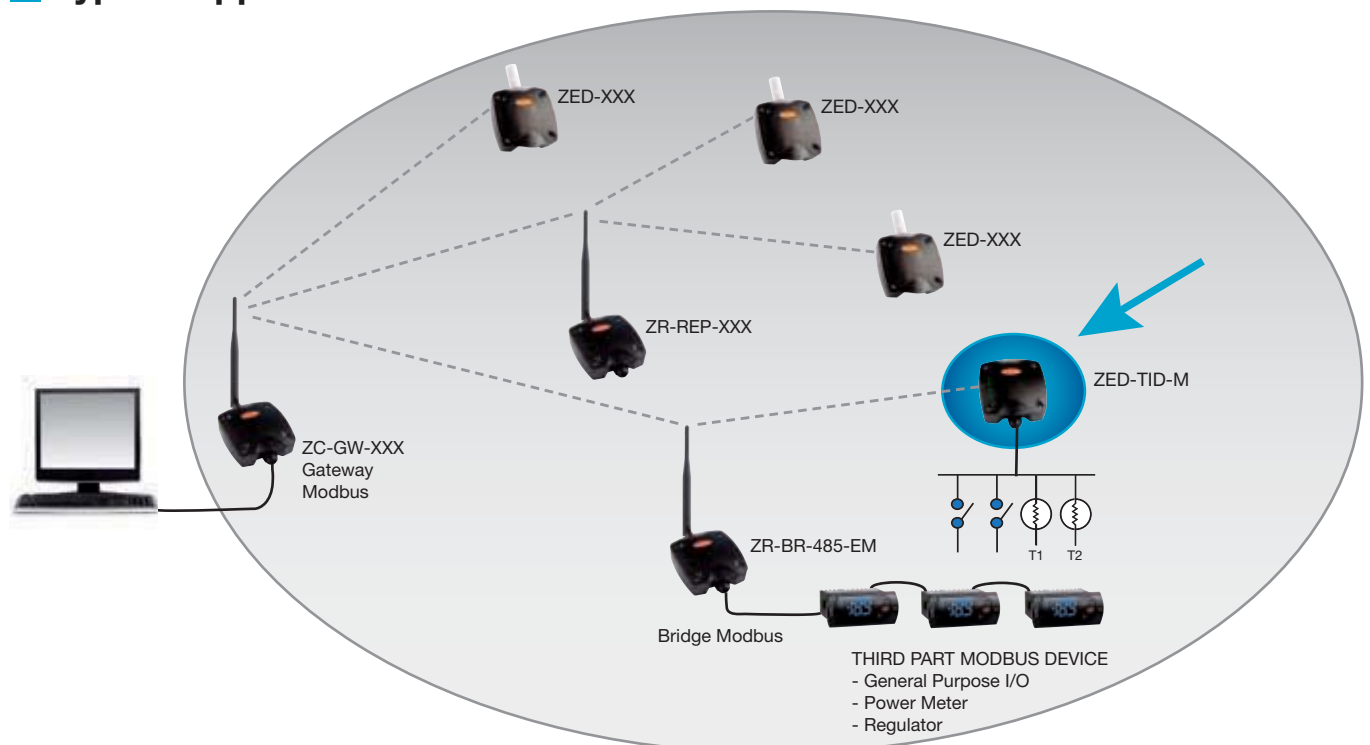

■ Technical Specs

General characteristics	Chip Ember EM250 Compatible IEEE 802.15.4 Stack EmberZnet 3.4.x (ZigBee PRO) Modbus/RTU Device address settable via internal dip-switch Wall mounting with screws Cable gland: PG9
RF characteristics	Frequency: 2405 MHz ÷ 2480 MHz Modulation: DSSS Nominal transmission power: 2mW (3 dBm) Reception sensitivity: -95 dBm Internal antenna gain: 0 dB Coverage outdoor/indoor: 100m/30m
Supply	AA high energy density lithium battery 3,6V/2000mAh Battery life: 3 years in case of 1 transmission per minute at 20°C
Thermal sensor input	NTC sensor 103AT type (R25 = 10 KOhm; Beta = 3435K) Measurement range: -50°C ÷ +100°C Measurement resolution: 0,1°C Measurement accuracy: ±0,5°C Measures are linearized at tenth of degree
Digital inputs	Electronic type not insulated inputs for clean contact Short circuit current 0,01mA. Use self-cleaning contacts
Connections	Pull out terminals (3,81 mm pitch)
Environment parameters	Operating temperature: -10 ÷ +60°C; <80% U.R. not condensing Storage temperature: -20 ÷ +70°C; <80% U.R. not condensing Degree of protection: IP 55
Compliant with 2006/95/EEC, 89/336/EEC, 99/5/EEC directives Reference Norms:	ETSI EN 300 328: Radio Compatibility for digitals wide band transmissions ETSI EN 301 489: Radio Compatibility EN 61000-6-2: Electromagnetic Compatibility - Emissions EN 61000-6-3: Electromagnetic Compatibility - Immunity EN 60950-1: Electric Safety

■ Dimensions (mm)

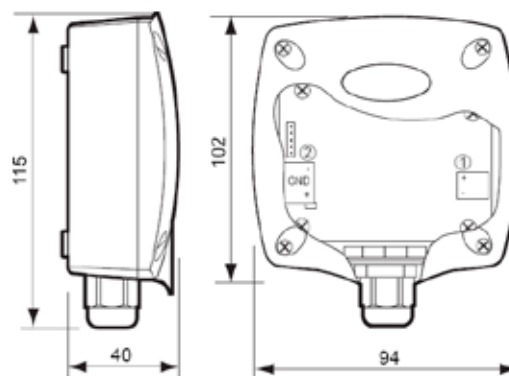

Rev 2.4 30/09/2009

 **ZB-Connection** is a 4-noks brand

4-noks is a  **ZigBee**
Member

4-noks

4-noks Distributor:

4-noks s.r.l.
Via Dei Gelsi, 19
31010 Godega di Sant'Urbano - Treviso - Italy
Tel. (+39) 0438.1910013
info@4-noks.com - www.4-noks.com