

ZED-ICC-M

ZigBee hall effect sensor for direct current measurements



Key Features

- Hall effect sensor for direct current measurements
- Range between 0 and 1000A
- Simple and quick installation, without services interruptions
- Alarm thresholds
- Sampling and transmission rates are configurable
- Battery powered
- Internal antenna

The ZED-ICC-M is a battery powered ZigBee device that can perform direct current measurements through the Hall effect sensor and send them at regular intervals to one of a Gateway of the 4-noks products family.

This measure is based on the magnetic effect caused by the electric current flow along the conductor. To properly use this sensor, it should be placed on the conductor at a distance that is proportional to the amount of current that is to be measured. The range is between 0 and 1000 Acc.

This device may be configured to manage alarm thresholds for exceeding maximum or minimum current levels. It is also possible to adjust the sampling and data transmission rate to improve battery life.

Typical Application

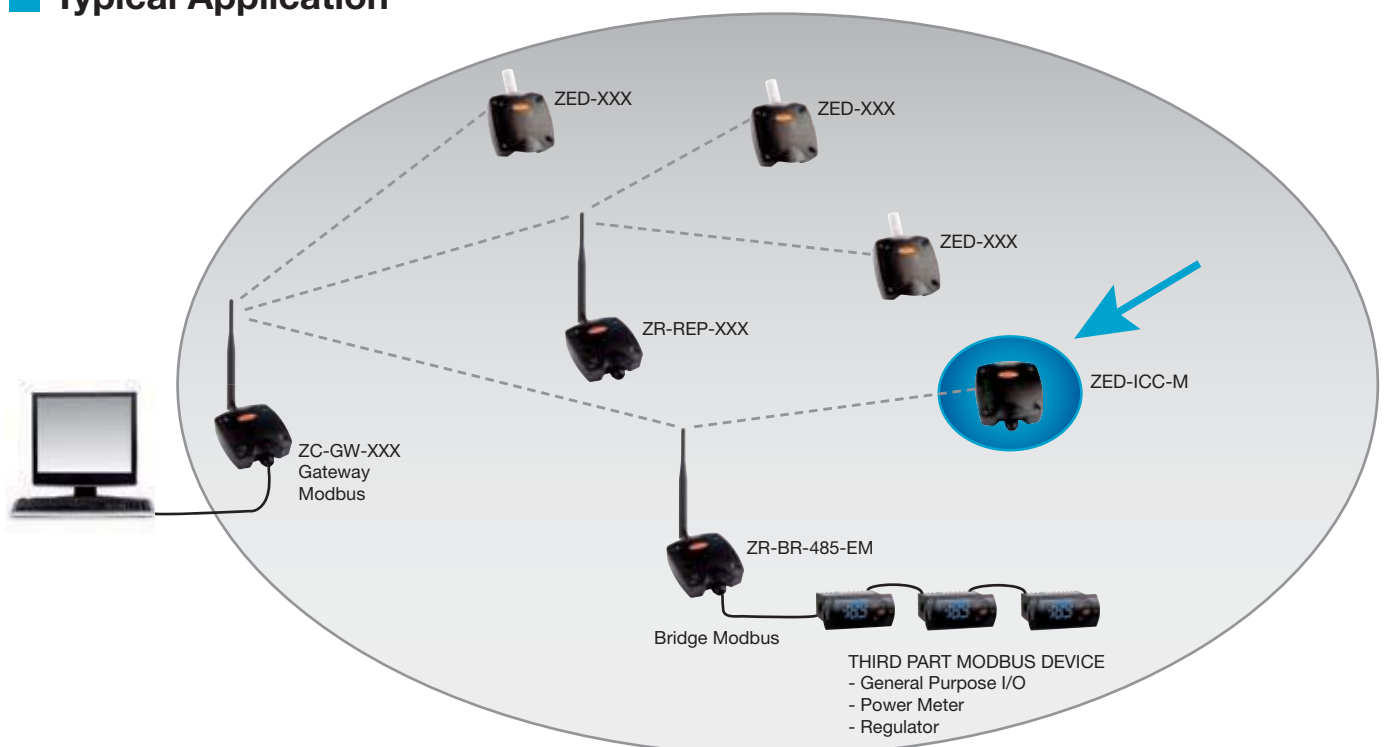

Technical Specs

General characteristics	Chip Ember EM250 Compatible IEEE 802.15.4 Stack EmberZnet 3.4.x (ZigBee PRO) Modbus/RTU Device address settable via internal dip-switch Mounting on conductor which current is to be measured
RF characteristics	Frequency: 2405 MHz ÷ 2480 MHz Modulation: DSSS Nominal transmission power: 2mW (3 dBm) Reception sensitivity: -95 dBm Internal antenna gain: 0 dB Coverage outdoor/indoor: 100m/30m
Supply	AA high energy density lithium battery 3,6V/2000mAh Battery life: 2 years in case of 1 transmission per minute at 20°C
Direct current sensor	Hall effect CSA-1V type sensor non-linearity error <1% Sensitivity 280 V/T Linear measurement range -5 mT ÷ +5 mT Response time < 6µs Measures represented in tenths of Ampere
Environment parameters	Operating temperature: -10 ÷ +60°C; <80% U.R. not condensing Storage temperature: -20 ÷ +70°C; <80% U.R. not condensing Degree of protection: IP 55
Compliant with 2006/95/EEC, 89/336/EEC, 99/5/EEC directives Reference Norms:	ETSI EN 300 328: Radio Compatibility for digitals wide band transmissions ETSI EN 301 489: Radio Compatibility EN 61000-6-2: Electromagnetic Compatibility - Emissions EN 61000-6-3: Electromagnetic Compatibility - Immunity EN 60950-1: Electric Safety

Dimensions (mm)

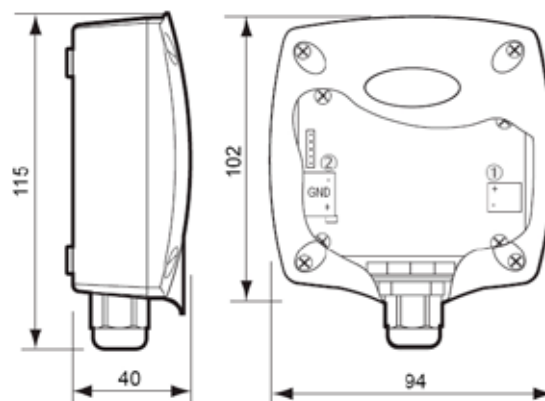

Rev 2.5 09/10/2009

 **ZB-Connection** is a 4-noks brand

4-noks is a  **ZigBee**
Member

4-noks

4-noks s.r.l.
Via Dei Gelsi, 19
31010 Godega di Sant'Urbano - Treviso - Italy
Tel. (+39) 0438.1910013
info@4-noks.com - www.4-noks.com

4-noks Distributor:

